



Marine
No. M-850BP

Ignition Switch Off-Run-Start

Spring return from Start to Run

- Functions like automotive switches: 'Run' position activates accessories such as radio, radar, blower, lights, etc.
- Heavy grade impact-resistant plastic body, cannot rust or corrode.
- 3 nickel-silver terminals for high conductivity and resistance to corrosion. 15A Ignition, 20A Start
- Multiple key codes provide added security. Some other ignition switches have one key that fits every lock.
- Plastic boot at key end gives extra weather-resistance.

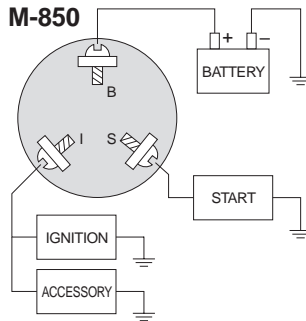

Installation

Installs in panels up to 7/8" thick, through standard 7/8" hole.

1. Turn the power Off, using the Master Disconnect Switch, or by removing the positive cable from the battery.
2. Remove old switch from the panel.
3. Transfer the wires from the old switch (one at a time) to the new switch.
4. Install the new switch using the provided hardware. Either of the drain holes must face down.

Cole Hersee Company
20 Old Colony Avenue
Boston, MA 02127-2467
www.colehersee.com

Fits *Bayliner*, *ChrisCraft*, *Sea Ray*. Suitable replacement for *General* 3976, 4107; *Sierra* 18-1803, 18-1802; *Pollak* 33-105; *Johnson* 393301; *Evinrude* 508180; *Mercury* 87-17009 AZ, 87-88107